



CC325L
3.2 x 2.5 x 0.95 mm
LCC Ceramic Package

Features

- Quartz crystal controlled precision square wave oscillator
- CMOS Output (will interface with TTL devices)
- Enable/Disable Function includes low standby power
- Low Jitter
- 3.3V nominal Supply Voltage
- 1.25 - 170 MHz Frequency Range

Applications

Driving A/Ds, D/As, FPGAs
Digital Video
Ethernet, GbE
Medical
Storage Area Networking
COTS
Broad Band Access
SONET/ SDH/ DWDM
Base Stations/ Picocell
Test & Measurement

Electrical Characteristics

Parameter	Min	Typ	Max	Unit	Condition
Frequency Range ²	1.25	-	170	MHz	
Frequency Stability ²	±20*	-	±50	ppm	Includes supply voltage change, load change, aging for 1 year at 25°C ± 2°C, shock, vibration and temperatures. *limited frequencies, see page 2
Operating Temperature Range options ²	-10 -20 -40	-	+70 +70 +85	°C	
Supply Voltage ^{1,2} V _{CC}	2.97	3.30	3.63	V	
Output Waveform	CMOS				
Duty Cycle	45	-	55	%	At 50% V _{CC}
Output V _{HIGH} (V _{OH})	V _{CC} - 0.4	-	-	V	See Load Circuit
Output V _{LOW} (V _{OL})	-	-	0.4	V	
Output T _{RISE} and T _{FALL}	-	1	5	ns	C _{LOAD} = 15 pF 10% to 90% of V _{CC} See Load Circuit
Startup Time	-	-	10	ms	Time for output to reach specified frequency
V _{DISABLE} (V _{IL})	-	-	30	%	Of V _{CC} applied to Pad 1
V _{ENABLE} (V _{IH})	70	-			
Enable Time	-	-	100	ns	Time for output to reach a logic state
Disable Time	-	-	200	ns	Time for output to reach a high Z state
Enable/Disable Internal Pull-up	30	70	150	KΩ	To V _{CC}
Output Leakage	V _{OUT} = V _{CC} -10	-	+10 -	μA	Pad 1 low, device disabled
Standby Current	V _{OUT} = 0V	-	10	μA	
rms Phase Jitter	-	0.1	1.0	ps	F _o ≥ 40MHz; 12kHz ~ 20MHz
Phase Noise	10 Hz 100 Hz 1 kHz 10 kHz 100 kHz 1 MHz 10 MHz	-	-78 -107 -132 -144 -151 -155 -158	-	dBc/Hz 25°C ± 2°C at 100 MHz
Storage Temperature Range	-55	-	+125	°C	

Notes: Specifications with Pad 1 E/D open circuit

¹ Place an appropriate power supply bypass capacitor next to device for correct operation

² Specified by part number

Electrical Characteristics						
Parameter	Min	Typ	Max	Unit	Condition	
Supply Current I_{CC}	-	0.9	1.8	mA	3 MHz	3.3V, no load
		1.4	2.8		5 MHz	
		1.5	3.0		10 MHz	
		1.7	3.4		20 MHz	
		3.5	7.0		50 MHz	
		4.0	8.0		65 MHz	
		4.5	9.0		85 MHz	
		5.5	10.5		100 MHz	
		7.0	13.5		125 MHz	

Specifications with Pad 1 E/D circuit open

Part Number							
Series Model	Supply Voltage	Packaging		Operating Temperature Range	Frequency Stability	Symmetry	Frequency
CC325	L	Z	-	A2	BR	45	-50.0
	L = 3.3V ± 10%	Z = Tape/Reel Blank = Tape only		A1 = -10 to +70°C A5 = -20 to +70°C A2 = -40 to +85°C*	B9 = ±20 ppm* BR = ±25 ppm B2 = ±50 ppm Blank = ±100 ppm	45 = 45/55%	

* Contact Cardinal sales for limited frequencies. Full frequency range available which excludes aging.

Cardinal Components Inc. certifies this device is in accordance with the RoHS and REACH directives.

Cardinal guarantees the device does not contain the following: Cadmium, Hexavalent Chromium, Lead, Mercury, PBB's, PBDE's
 Weight of the Device: 0.024 grams
 Moisture Sensitivity Level: 1 As defined in J-STD-020D
 Second Level Interconnect code: e4

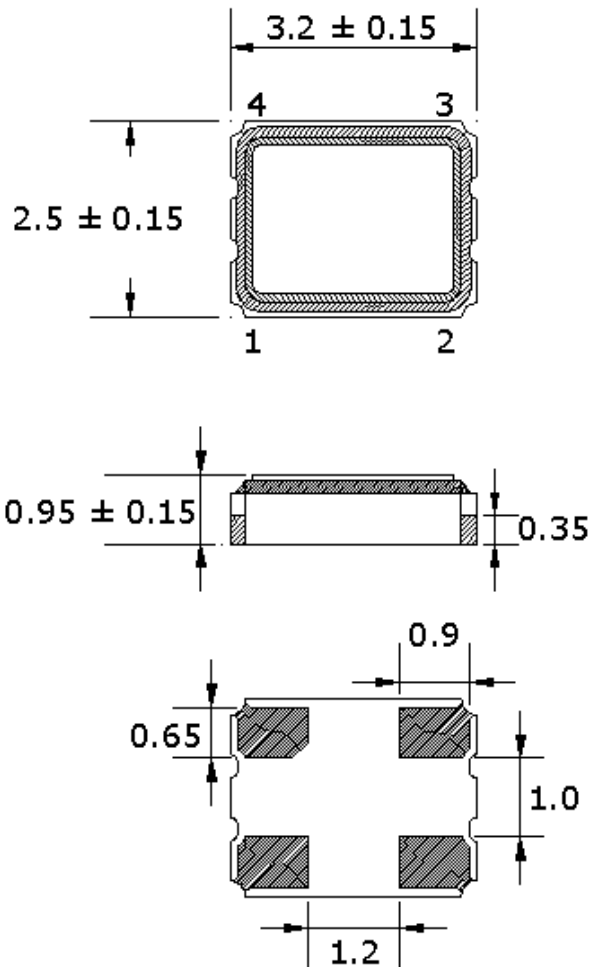
Mechanical Dimensions

Pad Connections

Pad	Function
1	Enable/Disable
2	Ground
3	Output
4	Vcc

ENABLE/DISABLE

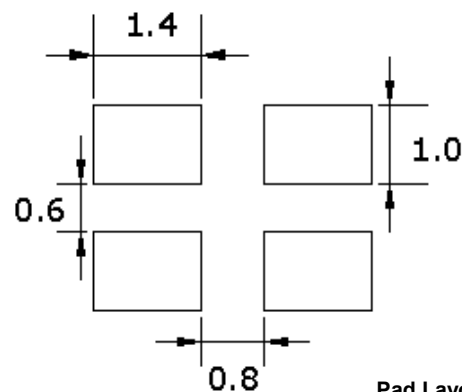
Pad 1	Output
V _{IH} /Open	Active
V _{IL} /Gnd	Disabled/Tristate

Pad Layout

Disclaimer: Recommended layout shown. Adjust layout as needed for individual process requirements.

Dimensions in mm

Contacts (pads): Gold (0.3 to 1.0 μm) over Nickel (1.27 to 8.89 μm)

For Optimum Jitter Performance, Cardinal recommends:

- A ground plane under the device
- Do not route large transient signals (both current and voltage) under the device
- Do not place near a large magnetic field such as a high frequency switching power supply
- Do not place near piezoelectric buzzers or mechanical fans

Electrical Test / Load Circuit

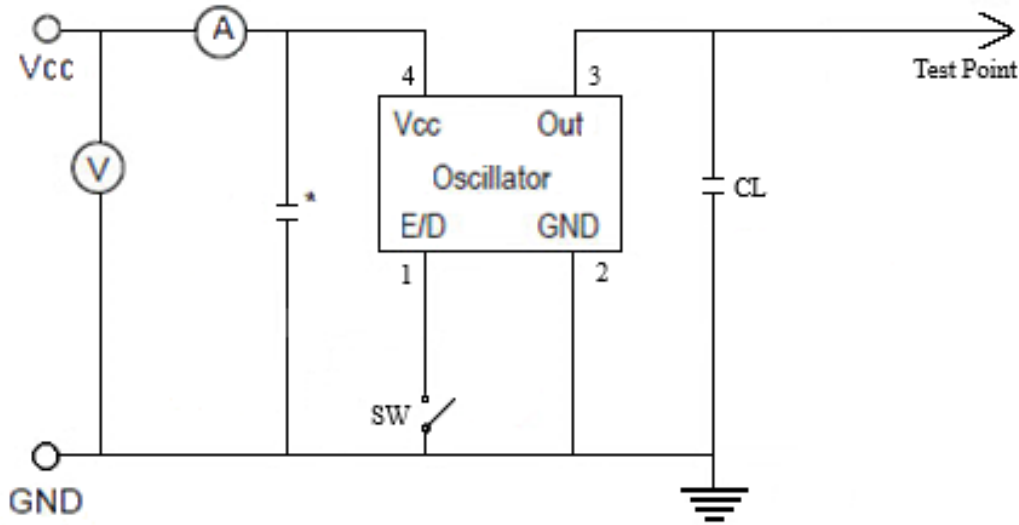

Notes:

CL: Includes the input capacitance of oscilloscope

* 0.01 μ F external by-pass filter is recommended

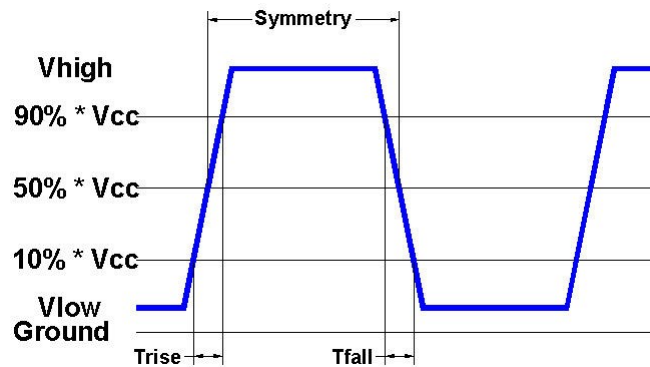

Environmental / ESD Ratings

Reliability: Environmental

Parameter	Condition
Mechanical Shock	MIL-STD-883, Method 2002, Condition B
Vibration	MIL-STD-883, Method 2007, Condition A
Solderability	IPC J-STD-002
Thermal Cycle	MIL-STD-883 Method 1010, Condition B

ESD Rating

Model	Min. Voltage	Condition
Human Body Model	2000V	JESD22-A114
Machine Model	200V	JESD22-A115

Absolute Maximum Ratings

Parameter	Unit
V _{CC} Supply Voltage	-0.3V to +4.0V
V _i Input Voltage	-0.3V to V _{CC} + 0.3V
V _o Output Voltage	-0.3V to V _{CC} + 0.3V

Thermal Characteristics:

The maximum die or junction temperature is 150°C

Reflow Cycle

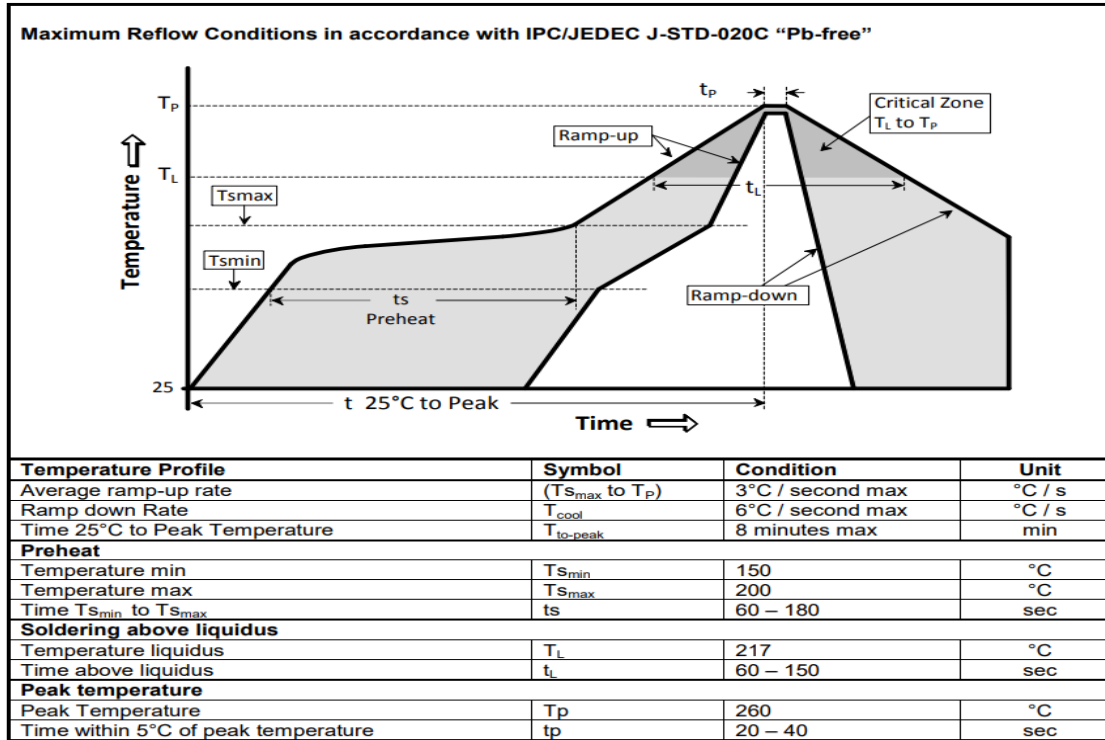

The part may be reflowed 2 times without degradation (typical for lead free processing).

Tape and Reel

Tape and Reel available for quantities of 250 to 3000 per reel, cut tape for < 250. 8mm tape, 4mm pitch.

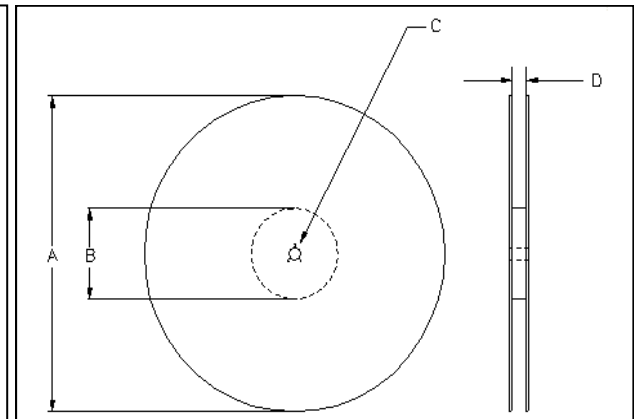
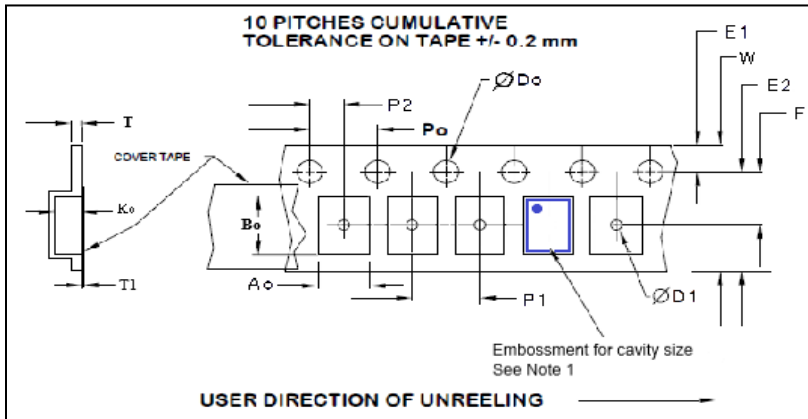

Tape Size	E2 typ	F	P1	W max	Ao	Bo	Ko
8mm	6.25	3.5 ±0.05	4.0 ±0.1	8.2	2.7±0.1	3.4±0.1	1.4±0.1

Reel Size	A		B		C	D
	Inches	mm	Inches	mm	mm	mm
7	7.0	180	2.50	60	13.0 +0.5 -0.2	Tape size +0.4 +2.0 -0.0

Dimensions in mm Drawing Not to scale
Note 1: Embossed cavity to conform to EIA-481-B

Tape Size	Do	D1 min	E1	Po	P2	T max	T1 max
8mm	1.5 +0.1 -0.0	1.0	1.75 ±0.1	4.0 ±0.1	2.0 ±0.05	0.3	0.1

Important Notice

Cardinal Components (CC) reserves the right to make corrections, improvements, modifications and other changes to this product at anytime. CC reserves the right to discontinue any product or service without notice. Customers are responsible for obtaining the latest relevant information before placing orders and should verify that such information is current and complete. All products are sold subject to CC's terms and conditions of sale supplied at the time of order acknowledgment.

CC warrants performance of this product to the specifications applicable at the time of sale in accordance with CC's limited warranty. Testing and other quality control techniques are used to the extent CC deems necessary to support this warranty. Except where mandated by specific contractual documents, testing of all parameters of each product is not necessarily performed.

CC assumes no liability for application assistance or customer product design. Customers are responsible for their products and applications using CC components. To minimize the risks associated with the customer products and applications, customers should provide adequate design and operating safeguards.

CC products are not designed, intended, authorized or warranted to be suitable for use in life support applications, weapons, weapon systems or space applications, devices or systems or other critical applications that may involve potential risks of death, personal injury or severe property or environmental damage. Inclusion of CC products in such applications is understood to be fully at the risk of the customer. Use of CC products in such applications requires the written approval of an appropriate CC officer. Questions concerning potential risk applications should be directed to CC.

CC does not warrant or represent that any license, either express or implied, is granted under any CC patent right, copyright, artwork or other intellectual property right relating to any combination, machine or process which CC product or services are used. Information published by CC regarding third-party products or services does not constitute a license from CC to use such products or services or a warranty or endorsement thereof. Use of such information may require a license from a third party under the patents or other intellectual property of the third party, or a license from CC under the patents or other intellectual property of CC.

Reproduction of information in CC data sheets or web site is permissible only if the reproduction is without alteration and is accompanied by associated warranties, conditions, limitations and notices. Reproduction of this information with alteration is an unfair and deceptive business practice. CC is not responsible or liable for such altered documents.

Resale of CC products or services with statements different from or beyond the parameters stated by CC for that product or service voids all express and implied warranties for the associated CC product or service and is an unfair or deceptive business practice. CC is not responsible for any such statements.

Contacting Cardinal Components

Cardinal Components
19013 36th Ave. West
Lynnwood, WA 98036-5761
U.S.A.

Tel: 973-785-1333
Fax: 425.776.2760
email: sales@cardinalxtal.com
URL: www.cardinalxtal.com