

5.0 x 3.2 x 1.2mm
LCC Ceramic Package

Features

- CMOS Output (will interface with TTL devices)
- Enable/Disable Function (low standby power option)
- Low Jitter
- 1.8V, 2.5V, or 3.3V nominal Supply Voltage
- 1-160 MHz Frequency Range (1-125MHz at 1.8V)
- Size: 5 x 3.2mm
- Configurable Oscillator

Applications

Driving A/Ds, D/As, FPGAs
Digital Video
Ethernet, GbE
Medical
Storage Area Networking
COTS
Broadband Access
SONET/ SDH/ DWDM
Test & Measurement

Electrical Characteristics

Parameter	Min	Typ	Max	Unit	Condition
Frequency Range ²	1	-	160	MHz	(1.8V frequency range 1-125MHz)
Frequency Stability ²	±20	-	±50	ppm	For all supply voltages, load changes, aging for 1 year at 25°C ± 2°C, shock, vibration and temperatures.
Operating Temperature Range options ²	0 -20 -40 -40	- - - -	+70 +70 +85 +105	°C	
Supply Voltage ^{1,2} V _{CC}	1.8	-	3.3	V	± 5%, See Part Number options on page 2
Supply Current I _{CC}	-	-	-	mA	See page 2
Output Waveform	CMOS				Clload = 15 pF
Duty Cycle	45	-	55	%	At 50%V _{CC} level
Output V _{OH}	90	-	-	%V _{CC}	See Load Circuit and waveform page
Output V _{OL}	-	-	10	%V _{CC}	
Output T _{RISE} and T _{FALL}	-	-	2	ns	
Startup Time	-	-	8	ms	Time for output to reach specified frequency
V _{DISABLE}	-	-	30	%	Of V _{CC} applied to Pad 1
V _{ENABLE}	70	-			
Enable Time	-	-	100	ns	Time for output to reach a logic state
Disable Time	-	-	100	ns	Time for output to reach a high Z state
Disable Current	- -	- 0.4	- -	mA	Enable/Disable: Pad 1 low, output disabled; See page 2 Standby option: Pad 1 low, output disabled, oscillator shutdown
Jitter	-	1.0	-	ps	12 kHz to 20 MHz @ 110 MHz
Storage Temperature Range	-55	-	+125	°C	

Notes: Specifications with Pad 1 E/D open circuit

¹ Place an appropriate power supply bypass capacitor next to device for correct operation

² Specified by part number

Input Current

Parameter	Min	Typ	Max	Unit	Condition V _{cc} = 3.3V	
Supply Current I _{cc}			27 30 35	mA	1MHz ≤ F _o < 75MHz 75MHz ≤ F _o < 125MHz 125MHz ≤ F _o < 160MHz	15pF load

Parameter	Min	Typ	Max	Unit	Condition V _{cc} = 2.5V	
Supply Current I _{cc}			27 30 35	mA	1MHz ≤ F _o < 75MHz 75MHz ≤ F _o < 125MHz 125MHz ≤ F _o ≤ 160MHz	15pF load

Parameter	Min	Typ	Max	Unit	Condition V _{cc} = 1.8V	
Supply Current I _{cc}			25	mA	1MHz ≤ F _o ≤ 125MHz	15pF load

Part Number Example: CPPYC5LZ-A7BP-125.0TS

Series Model	Logic	Package Size (mm)	Supply Voltage V _{cc}	Packaging	Operating Temperature Range	Frequency Stability	Frequency in MHz	Enable/Disable
CPPY	C	5	L	Z	A7	BP	125.0	TS
	C=CMOS	5 = 5 x 3.2	K = 1.8V J = 2.5V L = 3.3V	Blank=Tape Only Z= Tape/reel	Blank = 0 to +70°C A5 = -20 to +70°C A7 = -40 to +85°C AJ = -40 to +105°C	BD = ±20 ppm BR = ±25 ppm BP = ±50 ppm	1 - 160 MHz (1.8V: 1-125MHz)	TS = Tristate PD = Powerdown

Frequency Stability selection chart

	±20	±25	±50
0 - +70°C	•	•	•
-20 - +70°C	•	•	•
-40 - +85°C	△	•	•
-40 - +105°C		△	•

• - Available △ - Check with Cardinal

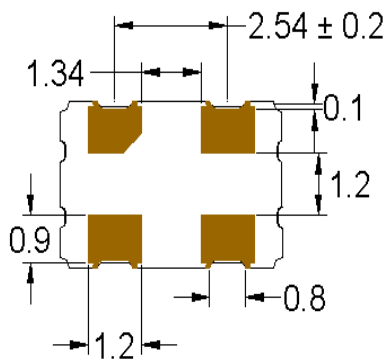
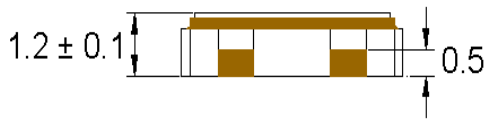
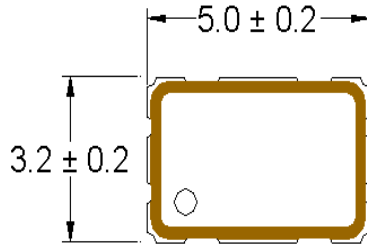
Mechanical Dimensions

Pad Connections

Pad	Function
1	Enable/Disable
2	Ground
3	Output
4	Vcc

ENABLE/DISABLE

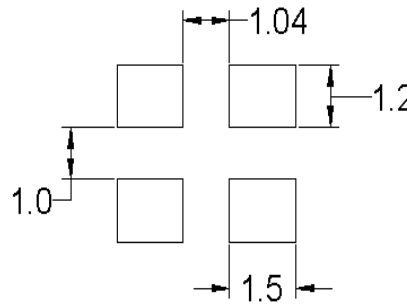
Pad 1	Output
V _{IH} /Open	Active
V _{IL} /Gnd	Disabled/Tristate

Pad Layout

Disclaimer: Recommended layout shown. Adjust layout as needed for individual process requirements.

Dimensions in mm

Contacts (pads): Gold (0.3 to 1.0 μm) over Nickel (1.27 to 8.89 μm)

Cardinal Components Inc. certifies this device is in accordance with the RoHS and REACH directives.

Cardinal Components guarantees the device does not contain the following: Cadmium, Hexavalent Chromium, Lead, Mercury, PBB's, PBDE's
 Weight of the Device: 0.058 grams
 Moisture Sensitivity Level: 1 As defined in J-STD-020D
 Second Level Interconnect code: e4

For Optimum Jitter Performance, Cardinal recommends:

- A ground plane under the device
- Do not route large transient signals (both current and voltage) under the device
- Do not place near a large magnetic field such as a high frequency switching power supply
- Do not place near piezoelectric buzzers or mechanical fans

Electrical Test / Load Circuit

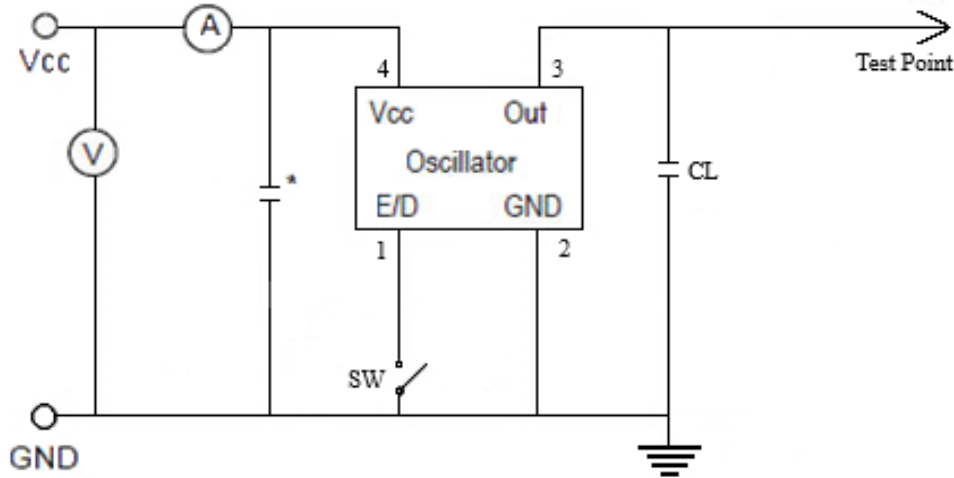

Notes:
 CL: 15pF Includes the input capacitance of oscilloscope
 * 0.01~0.1 μ F external by-pass filter is recommended

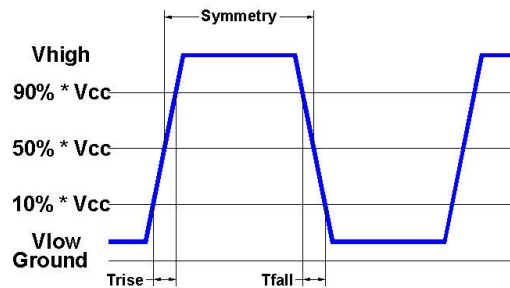

Environmental / ESD Ratings

Reliability: Environmental

Parameter	Condition
Mechanical Shock	MIL-STD-883, Method 2002, Condition B
Vibration	MIL-STD-883, Method 2007, Condition A
Solderability	IPC J-STD-002
Thermal Cycle	MIL-STD-883 Method 1010, Condition B

ESD Rating

Model	Min. Voltage	Condition
Human Body Model	2000V	MIL-STD-883 3015.7
Machine Model	200V	EIAJ ED-4701/304

Absolute Maximum Ratings

Parameter	Unit
V _{CC} Supply Voltage	-0.5V to +7.0V
V _I Input Voltage	-0.5V to V _{CC} + 0.5V
V _O Output Voltage	-0.5V to V _{CC} + 0.5V

Thermal Characteristics:

The maximum die or junction temperature is 125°C

Reflow Cycle

Maximum Reflow Conditions in accordance with IPC/JEDEC J-STD-020C "Pb-free"

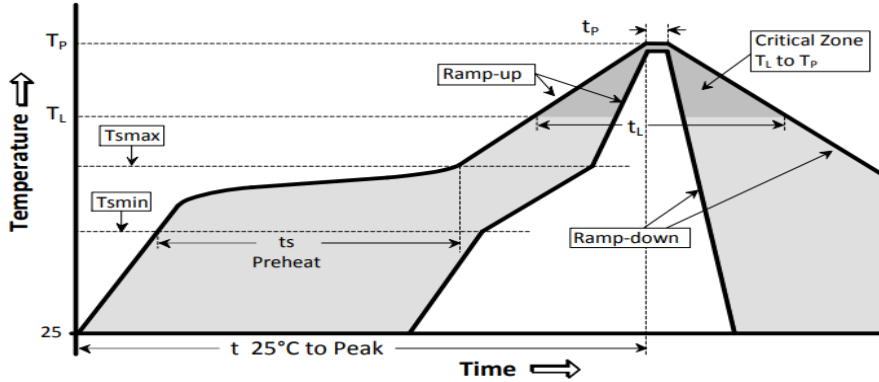

The part may be reflowed 2 times without degradation (typical for lead free processing).

Temperature Profile	Symbol	Condition	Unit
Average ramp-up rate	$(T_{Smax} \text{ to } T_P)$	3°C / second max	°C / s
Ramp down Rate	T_{cool}	6°C / second max	°C / s
Time 25°C to Peak Temperature	$T_{to-peak}$	8 minutes max	min
Preheat			
Temperature min	T_{Smin}	150	°C
Temperature max	T_{Smax}	200	°C
Time T_{Smin} to T_{Smax}	t_s	60 – 180	sec
Soldering above liquidus			
Temperature liquidus	T_L	217	°C
Time above liquidus	t_l	60 – 150	sec
Peak temperature			
Peak Temperature	T_P	260	°C
Time within 5°C of peak temperature	t_p	20 – 40	sec

Tape and Reel

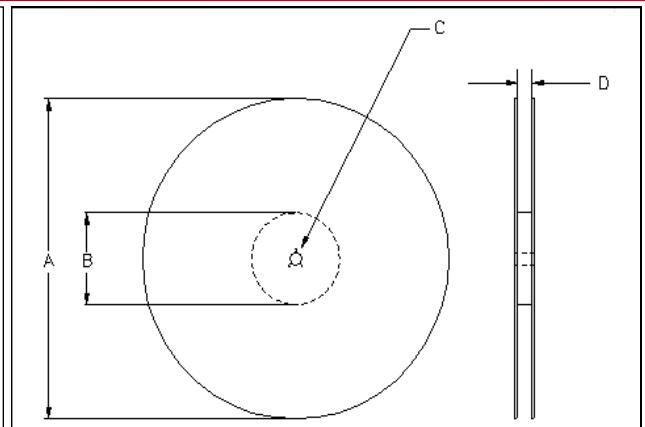
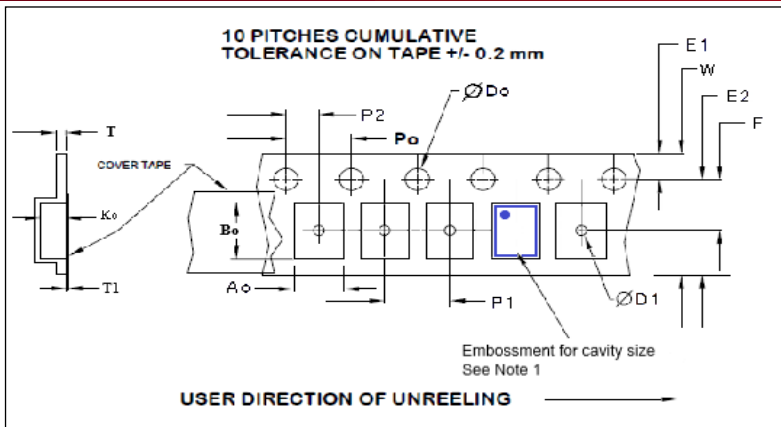

Part Size	Tape Size	E2 typ	F	P1	W max	A ₀	B ₀	K ₀	Qty/reel standard
5032	12mm	10.25	5.5 ±0.05	8.0 ±0.1	12.2	3.6±0.1	5.4±0.1	1.4±0.1	1K

Reel Size	A		B		C	D
	Inches	mm	Inches	mm	mm	mm
7	7.0	180	2.50	60	13.0 +0.5 -0.2	Tape size +0.4 +2.0 -0.0

Dimensions in mm Drawings Not to scale
Note 1: Embossed cavity to conform to EIA- 481-B

Tape Size	Do	D1 typ	E1	Po	P2	T typ	T1 max
12mm	1.5 +0.1 -0.0	1.5	1.75 ±0.1	4.0 ±0.1	2.0 ±0.05	0.3	0.1

Important Notice

Cardinal Components (CC) reserves the right to make corrections, improvements, modifications and other changes to this product at anytime. CC reserves the right to discontinue any product or service without notice. Customers are responsible for obtaining the latest relevant information before placing orders and should verify that such information is current and complete. All products are sold subject to CC's terms and conditions of sale supplied at the time of order acknowledgment.

CC warrants performance of this product to the specifications applicable at the time of sale in accordance with CC's limited warranty. Testing and other quality control techniques are used to the extent CC deems necessary to support this warranty. Except where mandated by specific contractual documents, testing of all parameters of each product is not necessarily performed.

CC assumes no liability for application assistance or customer product design. Customers are responsible for their products and applications using CC components. To minimize the risks associated with the customer products and applications, customers should provide adequate design and operating safeguards.

CC products are not designed, intended, authorized or warranted to be suitable for use in life support applications, weapons, weapon systems or space applications, devices or systems or other critical applications that may involve potential risks of death, personal injury or severe property or environmental damage. Inclusion of CC products in such applications is understood to be fully at the risk of the customer. Use of CC products in such applications requires the written approval of an appropriate CC officer. Questions concerning potential risk applications should be directed to CC.

CC does not warrant or represent that any license, either express or implied, is granted under any CC patent right, copyright, artwork or other intellectual property right relating to any combination, machine or process which CC product or services are used. Information published by CC regarding third-party products or services does not constitute a license from CC to use such products or services or a warranty or endorsement thereof. Use of such information may require a license from a third party under the patents or other intellectual property of the third party, or a license from CC under the patents or other intellectual property of CC.

Reproduction of information in CC data sheets or web site is permissible only if the reproduction is without alteration and is accompanied by associated warranties, conditions, limitations and notices. Reproduction of this information with alteration is an unfair and deceptive business practice. CC is not responsible or liable for such altered documents.

Resale of CC products or services with statements different from or beyond the parameters stated by CC for that product or service voids all express and implied warranties for the associated CC product or service and is an unfair or deceptive business practice. CC is not responsible for any such statements.

Contacting Cardinal Components

Cardinal Components
19013 36th Ave. West
Lynnwood, WA 98036-5761
U.S.A.

Tel: 973-785-1333
Fax: 425.776.2760
email: sales@cardinalxtal.com
URL: www.cardinalxtal.com