

CTXXPC3
3.2 x 2.5 x 1.6 mm
Leadless Ceramic Package

Features

- Quartz crystal controlled PLL Based TCXO
- CMOS Output
- Enable/Disable Function on pad 2
- 2.5V and 3.3V Supply Voltages

Applications

Driving A/Ds, D/As, FPGAs
Fibre Channel
Ethernet, GbE, SynchE
SONET
Storage Area Networking
Broadband
Telecom
Smart Grid

Electrical Characteristics

Parameter	Min	Typ	Max	Unit	Condition
Frequency Range	10		250	MHz	
Frequency Stability	±2.0	-	±2.5	ppm	Specified by part number; (f _{max} - f _{min}) / 2
Operating Temperature Range	-40	-	+85	°C	See Part Number guide for options
Storage Temperature Range	-55		+125	°C	
Supply Voltage ¹ V _{DD}	2.375 2.97	2.5 3.3	2.625 3.63	V	TV _{DD} ramp = 100µs min
Supply Current I _{DD}	-	20	40	mA	CL = 15 pF
Disable Current	-	16	-	mA	Pin 2 low
Output Waveform	CMOS				CL = 15 pF
Output High Voltage (V _{OH})	0.9*V _{DD}	-	-	V	
Output Low Voltage (V _{OL})	-	-	0.1*V _{DD}	V	
Output T _{RISE} and T _{FALL}			3.0	ns	V _{th} is 10% and 90% of V _{DD}
Startup Time	-	-	10	ms	Time for output to reach specified frequency
Duty Cycle	45	-	55	%	At 50% V _{DD} level
Enable/Disable Pullup	-	900	-	kΩ	Pin 2 to V _{DD}
V _{DISABLE} (V _{IL})	-	-	0.3*V _{DD}	V	Referenced to Ground
V _{ENABLE} (V _{IH})	0.7*V _{DD}	-	-		
Phase Noise	1 kHz 10 kHz 100 kHz 1 MHz 10 MHz 20 MHz	-	-111 -118 -119 -134 -155 -156	-	dBc/Hz 25°C ± 2°C, 3.3V, 155.52MHz
Phase Jitter	-	0.9	-	ps rms	12 kHz to 20 MHz at 155.52 MHz ; F _o ≥ 40MHz
Aging	-	-	±1.0	ppm	Per year, +25°C ± 2°C

Part Number

Example: CTXXPC3LZLD-100.0

Series Model	Output	Package Size	Supply Voltage	Packaging	Operating Temperature Range	Frequency Stability	Frequency (MHz)
CTXXP	C	3	L	Z	L	D	100.0
	C = CMOS	3 = 3.2x2.5mm	S = 2.5V L = 3.3V	Blank = Tape only Z = Tape/Reel	C = -20 to +70°C H = -30 to +75°C D = -30 to +85°C L = -40 to +85°C	C = ±2.0 ppm D = ±2.5 ppm	

Notes: Specifications with Pad 1 E/D open circuit

¹ Place an appropriate power supply bypass capacitor next to device for correct operation

Mechanical Dimensions (mm)

[TOP VIEW]

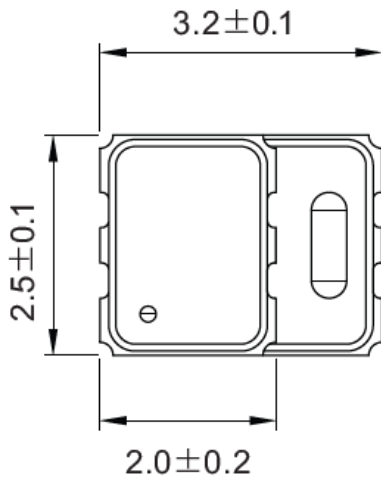

[BOTTOM VIEW]

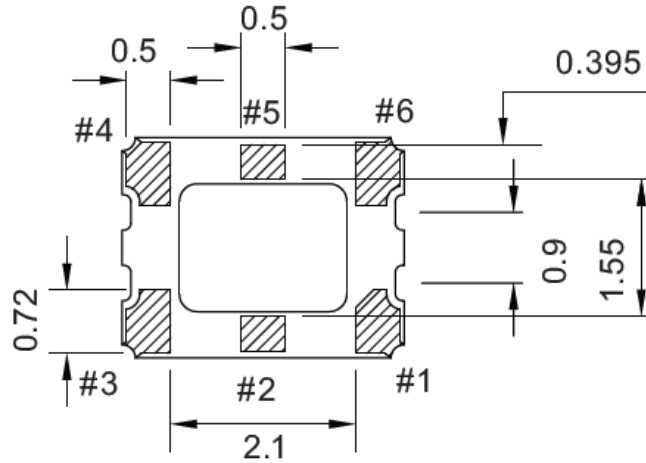

[SIDE VIEW]

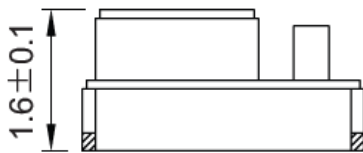

Type	CMOS
Pad	Function
1	No Connection
2	Tri-State
3	GND
4	Output
5	No Connection
6	VDD

Enable/Disable	
Pin 2	Output
Open	Active
Logic '1'	Active
Ground	Tri-state

Contacts (pads): Gold (0.3 to 1.0 μm) over Nickel (1.27 to 8.89 μm)

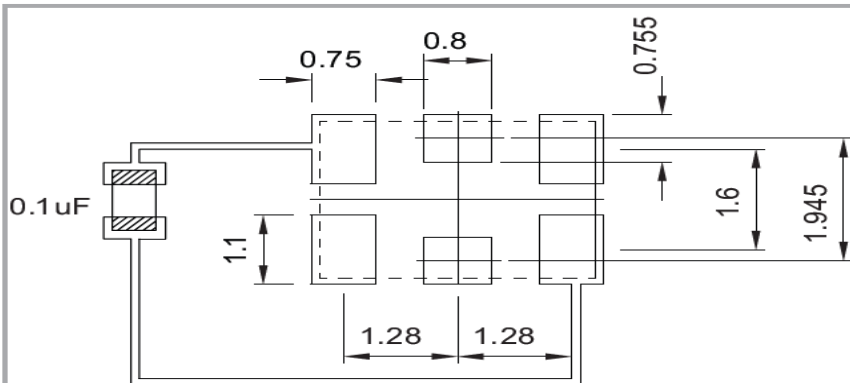

To ensure optimal oscillator performance, place a by-pass capacitor of 0.1 μF as close to the part as possible between Vdd and GND pads.

Pad Layout mm shown

Disclaimer: Recommended layout shown. Adjust layout as needed for individual process requirements.

For Optimum Jitter Performance, Cardinal recommends:

- A ground plane under the device
- Do not route large transient signals (both current and voltage) under the device
- Do not place near a large magnetic field such as a high frequency switching power supply
- Do not place near piezoelectric buzzers or mechanical fans

Electrical Test /Load Circuit

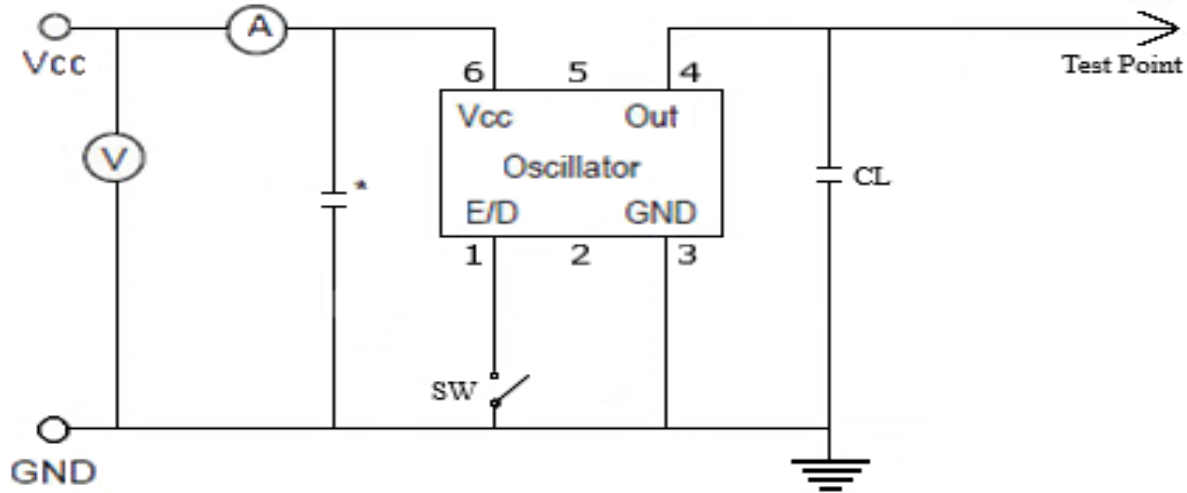

Test Waveform

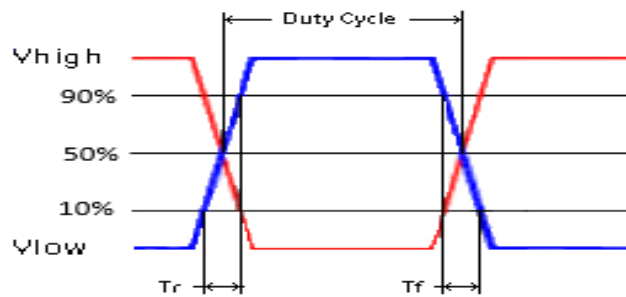

Environmental / ESD

Reliability: Environmental Test

Parameter	Reference Standard	Test Condition
Vibration	MIL-STD-883 2007 Condition A	10-2000Hz, 1.52mm, 20g, each axis for 4hrs
Thermal Shock	MIL-STD-883 1010 Condition B	-55°C, 125°C, soak time is 10 mins, with total 200 cycles
Mechanical Shock	MIL-STD-883 2002 Condition B	1500g, half-sine, 0.5ms, each axis for 3 times

Absolute Maximum Ratings

Parameter	Unit
V _{CC} Supply Voltage	-0.5V to +4.2V
V _i Input Voltage	-0.5V to V _{CC} + 0.5V
V _o Output Voltage	-0.5V to V _{CC} + 0.5V
Max Junction Temperature	125°C

ESD Rating

Model	Min. Voltage	Condition
Human Body Model	2000V	JESD22-A114
Charged Device Model	1000V	JESD22-C101
Machine Model	120V	JESD22-A115

Cardinal Components certifies this device is in accordance with the RoHS and REACH directives.

Cardinal Components guarantees the device does not contain the following: Cadmium, Hexavalent Chromium, Lead, Mercury, PBB's, PBDE's
 Weight of the Device: 0.028 grams
 Moisture Sensitivity Level: 1 As defined in J-STD-020D
 Second Level Interconnect code: e4

Reflow Cycle

Maximum Reflow Conditions in accordance with IPC/JEDEC J-STD-020C "Pb-free"

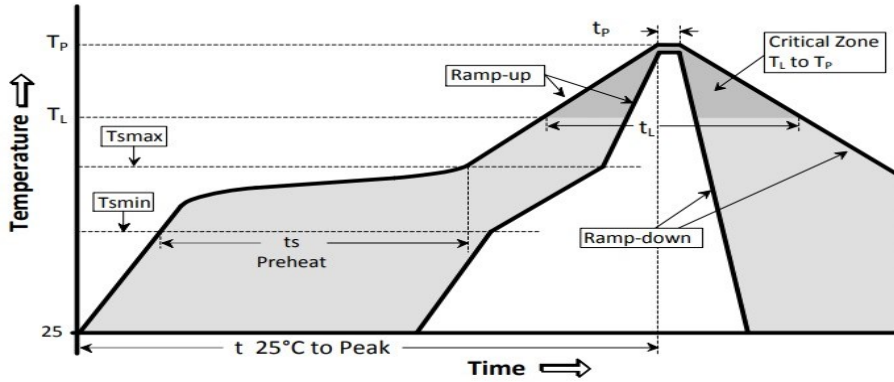

The part may be reflowed 2 times without degradation (typical for lead free processing).

Temperature Profile	Symbol	Condition	Unit
Average ramp-up rate	($T_{S_{max}}$ to T_P)	3°C / second max	°C / s
Ramp down Rate	T_{cool}	6°C / second max	°C / s
Time 25°C to Peak Temperature	$T_{to-peak}$	8 minutes max	min
Preheat			
Temperature min	$T_{S_{min}}$	150	°C
Temperature max	$T_{S_{max}}$	200	°C
Time $T_{S_{min}}$ to $T_{S_{max}}$	t_s	60 – 180	sec
Soldering above liquidus			
Temperature liquidus	T_L	217	°C
Time above liquidus	t_L	60 – 150	sec
Peak temperature			
Peak Temperature	T_p	260	°C
Time within 5°C of peak temperature	t_p	20 – 40	sec

Tape and Reel

Tape and Reel available for quantities of 250 to 3000 per reel, cut tape for < 250. 12mm tape, 4mm pitch.

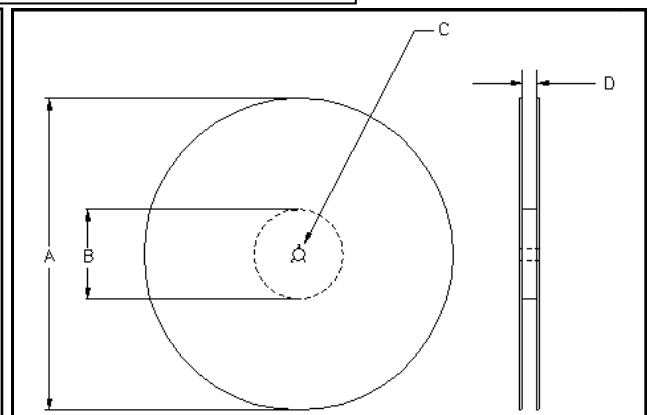
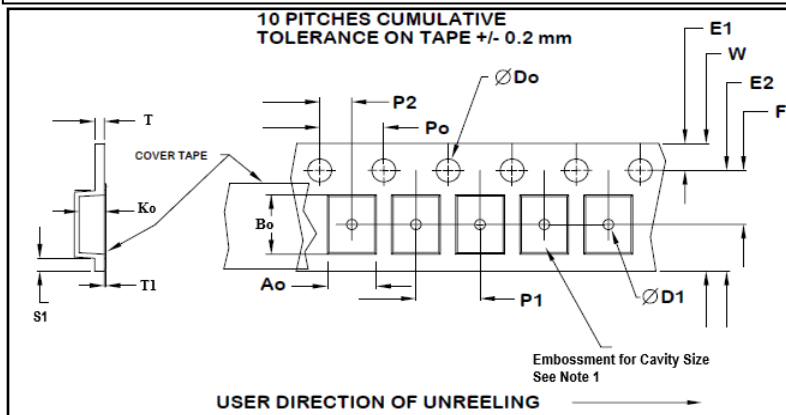

Tape Variable Dimensions Table 2

Tape Size	E2 typ	F	P1	W max	Ao	Bo	Ko
12mm	10.25	5.5 ± 0.05	4.0 ± 0.1	12.2	2.9 ± 0.1	3.6 ± 0.1	1.7 ± 0.1

Reel Dimensions (may vary) Table 3

Reel Size	A		B		C	D
	Inches	mm	Inches	mm	mm	mm
7	7.0	180	2.50	60	13.0 +0.5 -0.2	Tape size +0.4 +2.0 -0.0

Tape Constant Dimensions Table 1

Tape Size	Do	D1 typ	E1	Po	P2	T max	T1 max
12mm	1.5 +0.1 -0.0	1.5	1.75 ±0.1	4.0 ±0.1	2.0 ±0.1	0.3	0.1

Important Notice

Cardinal Components (CC) reserves the right to make corrections, improvements, modifications and other changes to this product at anytime. CC reserves the right to discontinue any product or service without notice. Customers are responsible for obtaining the latest relevant information before placing orders and should verify that such information is current and complete. All products are sold subject to CC's terms and conditions of sale supplied at the time of order acknowledgment.

CC warrants performance of this product to the specifications applicable at the time of sale in accordance with CC's limited warranty. Testing and other quality control techniques are used to the extent CC deems necessary to support this warranty. Except where mandated by specific contractual documents, testing of all parameters of each product is not necessarily performed.

CC assumes no liability for application assistance or customer product design. Customers are responsible for their products and applications using CC components. To minimize the risks associated with the customer products and applications, customers should provide adequate design and operating safeguards.

CC products are not designed, intended, authorized or warranted to be suitable for use in life support applications, weapons, weapons systems or space applications, devices or systems or other critical applications that may involve potential risks of death, personal injury or severe property or environmental damage. Inclusion of CC products in such applications is understood to be fully at the risk of the customer. Use of CC products in such applications requires the written approval of an appropriate CC officer. Questions concerning potential risk applications should be directed to CC.

CC does not warrant or represent that any license, either express or implied, is granted under any CC patent right, copyright, artwork or other intellectual property right relating to any combination, machine or process which CC product or services are used. Information published by CC regarding third-party products or services does not constitute a license from CC to use such products or services or a warranty or endorsement thereof. Use of such information may require a license from a third party under the patents or other intellectual property of the third party, or a license from CC under the patents or other intellectual property of CC.

Reproduction of information in CC data sheets or web site is permissible only if the reproduction is without alteration and is accompanied by associated warranties, conditions, limitations and notices. Reproduction of this information with alteration is an unfair and deceptive business practice. CC is not responsible or liable for such altered documents.

Resale of CC products or services with statements different from or beyond the parameters stated by CC for that product or service voids all express and implied warranties for the associated CC product or service and is an unfair or deceptive business practice. CC is not responsible for any such statements.

Contacting Cardinal Components

Cardinal Components
19013 36th Ave. West
Lynnwood, WA 98036-5761
U.S.A.

Tel: 973-785-1333
Fax: 425-776-2760
email: sales@cardinalxtal.com
URL: www.cardinalxtal.com