



CJVHE5
5.0 x 3.2 x 1.25 mm
LCC Ceramic Package

Features

- Quartz crystal controlled Precision Square Wave Oscillator
- LVPECL Output
- Voltage Control function
- Enable/Disable Function on pad 2
- 3.3V nominal Supply Voltage
- 10MHz - 1500MHz frequency range

Applications

Driving A/Ds, D/As, FPGAs
Fibre Channel
Ethernet, GbE, SynchE
Medical
Storage Area Networking
COTS
Telecom
PON

Electrical Characteristics					
Parameter	Min	Typ	Max	Unit	Condition
Frequency Range ²	10	-	1500	MHz	
Frequency pullability APR ²	-	±50	-	ppm	Absolute pull range, includes effect of temperature stability
Operating Temperature Range ²	-20 -40	-	+70 +85	°C	
Supply Voltage ^{1,2} V _{CC}	2.97	3.3	3.63	V	TV _{CC} ramp = 100µs min
Supply Current I _{CC}	-	54	-	mA	
Output Waveform	LVPECL				
Output Voltage High V _{OH}	V _{CC} - 1.03	-	V _{CC} - 0.6	V	
Output Voltage Low V _{OL}	V _{CC} - 1.85	-	V _{CC} - 1.6	V	
Output T _{RISE} and T _{FALL}	-	-	0.25	ns	V _{th} is 10% and 90% of amplitude
Startup Time	-	-	10	ms	Time for output to reach specified frequency
Duty Cycle	45	-	55	%	Referenced to 50% of amplitude or crossing point
V _{DISABLE}	-	-	0.3*V _{CC}	Volts	Referenced to Ground
V _{ENABLE}	0.7*V _{CC}	-	-		
Enable Time	-	-	200	ns	< 50MHz
	-	-	100	ns	≥ 50MHz
Disable Time	-	-	50	ns	Time for output to reach a high Z state
Control Voltage	0	1.65	3.3		
Modulation Bandwidth	10	-	-	kHz	
Voltage vs. Frequency Linearity	-	10	-	%	
Standby Current	-	18	-	mA	Pad 2 low, device disabled
Aging	-	-	±3.0	ppm	per year
Storage Temperature Range	-55	-	+125	°C	

Notes: Specifications with Pad 2 E/D open circuit

¹ Place an appropriate power supply bypass capacitor next to device for correct operation

² Defined by part number

Typical Phase Noise/Jitter			
Phase Noise	10 Hz 100 Hz 1 kHz 1 MHz 20 MHz	-66 -96 -112 -136 -154	dBc/Hz
Precision Developed Frequencies: 100, 106.25, 120, 150, 156.25, 162.5, 175, 187.5, 200, 212.5, 250.0, 312.5, 625.0MHz 25°C ± 2°C at 2.5V / 156.250 MHz			
Jitter	0.6	ps rms	12 kHz to 20 MHz from the output frequency @ 156.25Mhz
Phase Noise	10 Hz 100 Hz 1 kHz 1 MHz 20 MHz	-51 -88 -108 -135 -151	dBc/Hz
All Other Frequencies 25°C ± 2°C at 2.5V / 133 MHz			
Jitter	2.4	ps rms	12 kHz to 20 MHz from the output frequency @133MHz

Part Number (Example: CJVHE5LZ-A7BP-100.0TS)								
Series Model	Logic	Package size	Supply Voltage	Packaging	Operating Temperature Range	Pullability (APR)	Frequency MHz	Enable/Disable
CJVH	E	5	L	Z	A7	BP	100.0	TS
	E = LVPECL	5 = 5 x 3.2mm	L = 3.3V	Blank = Tape Only Z = Tape/Reel	A5 = -20 to +70°C A7 = -40 to +85°C	BP = ±50 ppm min	10 - 1500 MHz	TS=Tristate

Cardinal Components Inc. certifies this device is in accordance with the RoHS and REACH directives.

Cardinal Components guarantees the device does not contain the following: Cadmium, Hexavalent Chromium, Lead, Mercury, PBB's, PBDE's
 Weight of the Device: 0.09 grams
 Moisture Sensitivity Level: 1 As defined in J-STD-020D
 Second Level Interconnect code: e4

For Optimum Jitter Performance, Cardinal recommends:

- A ground plane under the device
- Do not route large transient signals (both current and voltage) under the device
- Do not place near a large magnetic field such as a high frequency switching power supply
- Do not place near piezoelectric buzzers or mechanical fans

Mechanical Dimensions (mm)

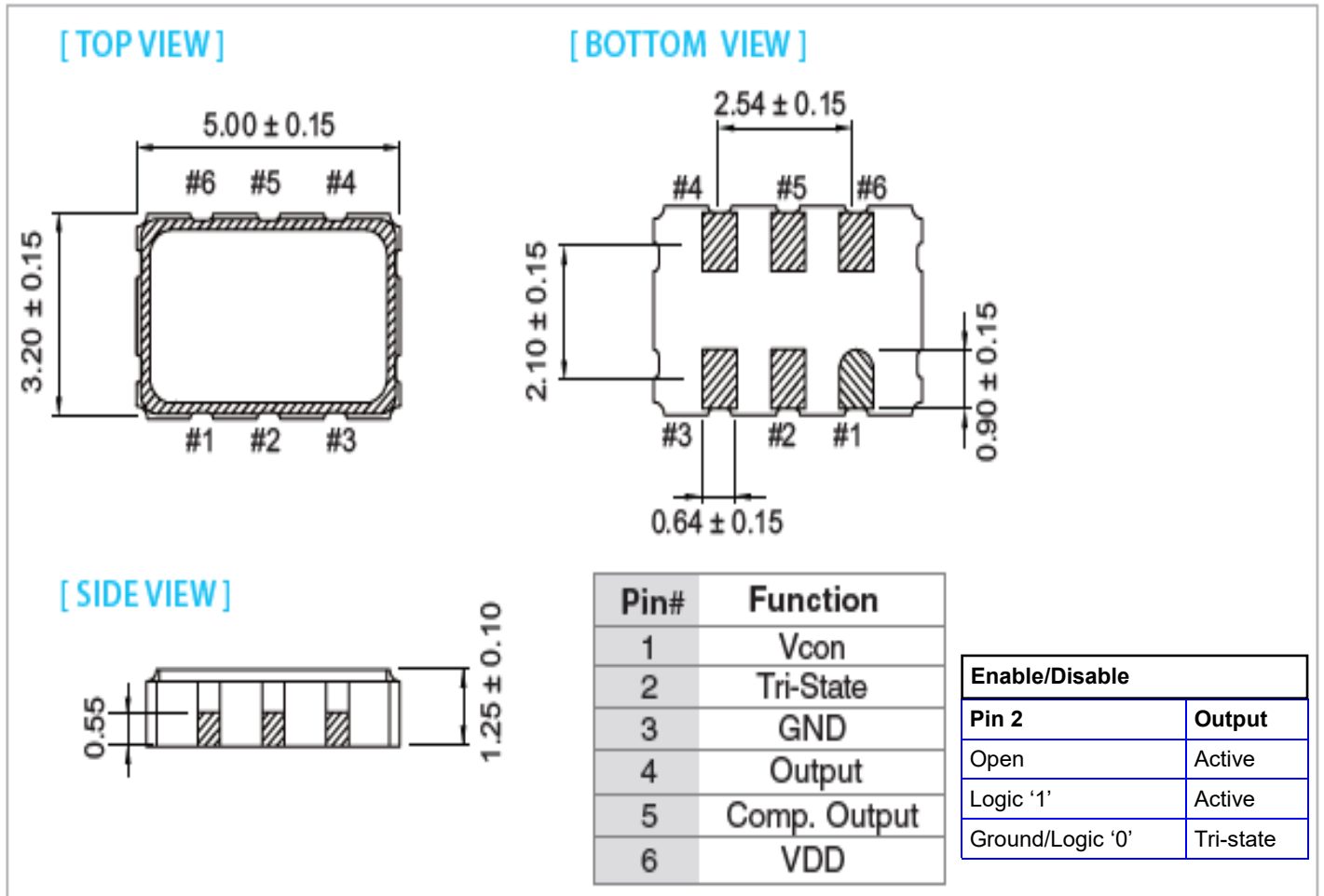

Contacts (pads): Gold (0.3 to 1.0 μm) over Nickel (1.27 to 8.89 μm)

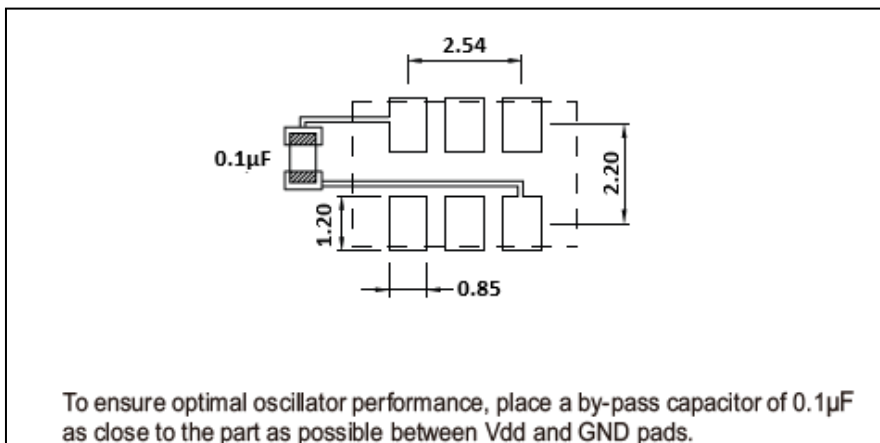

Pad Layout mm shown

Disclaimer: Recommended layout shown. Adjust layout as needed for individual process requirements.

For Optimum Jitter Performance, Cardinal recommends:

- A ground plane under the device
- Do not route large transient signals (both current and voltage) under the device
- Do not place near a large magnetic field such as a high frequency switching power supply
- Do not place near piezoelectric buzzers or mechanical fans

Electrical Test /Load Circuit

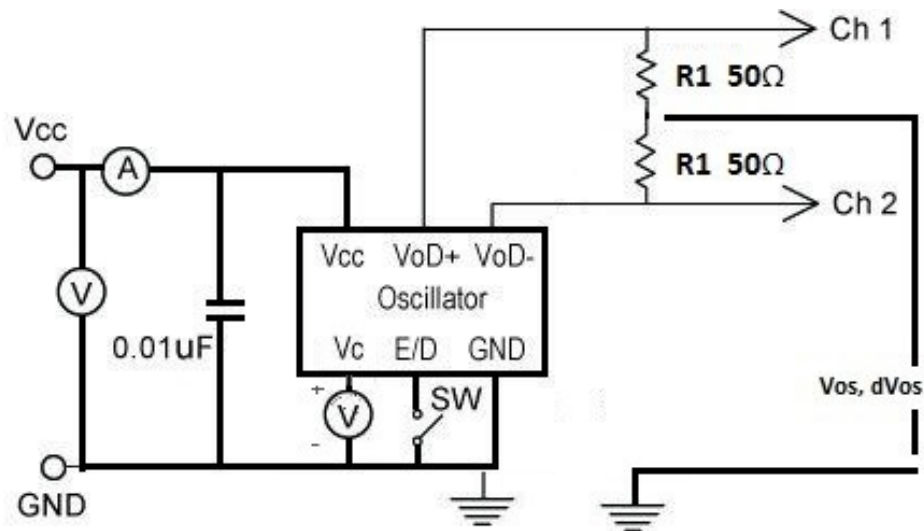

Test Waveform

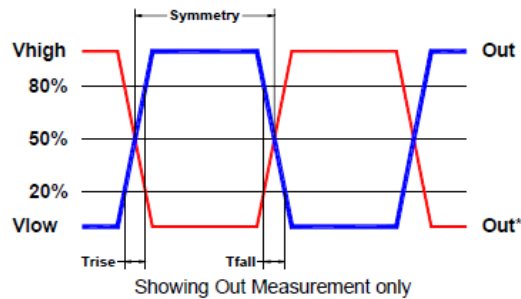

Environmental / ESD Ratings

Reliability: Environmental

Parameter	Condition
Mechanical Shock	MIL-STD-883, Method 2002, Condition B
Vibration	MIL-STD-883, Method 2007, Condition A
Solderability	IPC J-STD-002
Thermal Cycle	MIL-STD-883 Method 1010, Condition B

ESD Rating

Model	Min. Voltage	Condition
Human Body Model	2000V	JESD22-A114
Charged Device Model	1000V	JESD22-C101
Machine Model	120V	JESD22-A115

Absolute Maximum Ratings

Parameter	Unit
V _{cc} Supply Voltage	-0.5V to +4.2V
V _i Input Voltage	-0.5V to V _{cc} + 0.5V
V _o Output Voltage	-0.5V to V _{cc} + 0.5V

Thermal Characteristics:

The maximum die or junction temperature is 125°C

Reflow Cycle

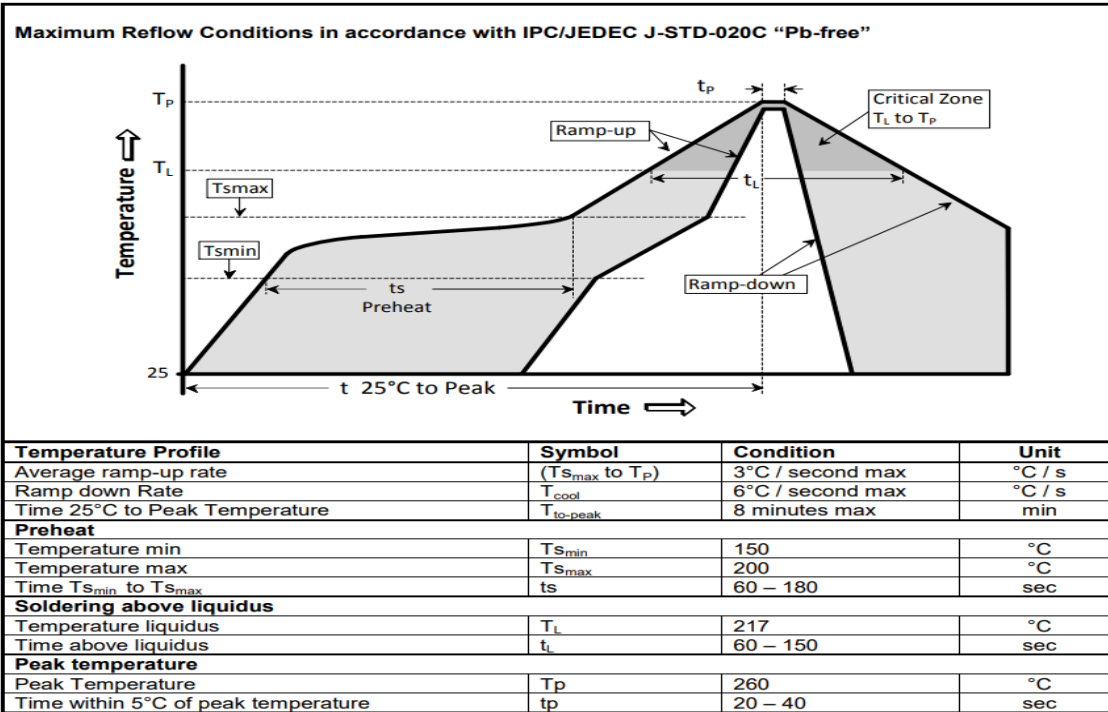

The part may be reflowed 2 times without degradation (typical for lead free processing).

Tape and Reel

Tape and Reel available for quantities of 250 to 1000 per reel, cut tape for < 250. 12mm tape, 8mm pitch.

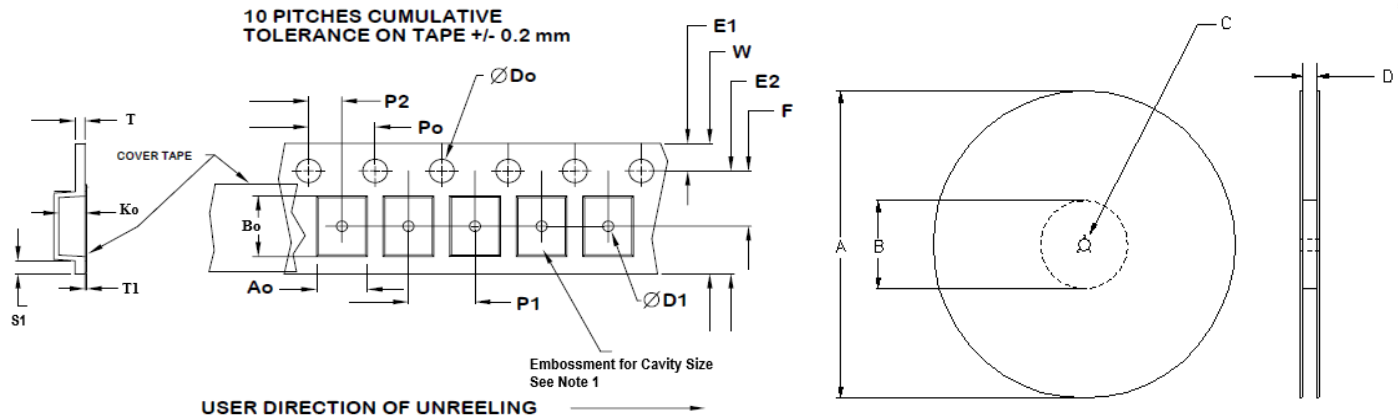

Tape Size	E2 typ	F	P1	W max	Ao	Bo	Ko
12mm	10.25	5.5 ±0.05	8.0 ±0.1	12.2	3.6±0.1	5.4±0.1	1.4±0.1

Dimensions in mm Drawing Not to scale

Note 1: Embossed cavity to conform to EIA- 481-B

Tape Size	Do	D1	E1	Po	P2	S1 min	T max	T1 max
12mm	1.5 +0.1 -0.0	1.5	1.75 ±0.1	4.0 ±0.1	2.0 ±0.1	0.6	0.3	0.1

Reel Size	A		B		C	D
	Inches	mm	Inches	mm		
7	7.0	177.8	2.50	63.5	13.0 +0.5 -0.2	Tape size +0.4 +2.0 -0.0
10	10.0	254.0	4.00	101.6		
13	13.0	330.2	3.75	95.3		

Important Notice

Cardinal Components (CC) reserves the right to make corrections, improvements, modifications and other changes to this product at anytime. CC reserves the right to discontinue any product or service without notice. Customers are responsible for obtaining the latest relevant information before placing orders and should verify that such information is current and complete. All products are sold subject to CC's terms and conditions of sale supplied at the time of order acknowledgment.

CC warrants performance of this product to the specifications applicable at the time of sale in accordance with CC's limited warranty. Testing and other quality control techniques are used to the extent CC deems necessary to support this warranty. Except where mandated by specific contractual documents, testing of all parameters of each product is not necessarily performed.

CC assumes no liability for application assistance or customer product design. Customers are responsible for their products and applications using CC components. To minimize the risks associated with the customer products and applications, customers should provide adequate design and operating safeguards.

CC products are not designed, intended, authorized or warranted to be suitable for use in life support applications, weapons, weapons systems or space applications, devices or systems or other critical applications that may involve potential risks of death, personal injury or severe property or environmental damage. Inclusion of CC products in such applications is understood to be fully at the risk of the customer. Use of CC products in such applications requires the written approval of an appropriate CC officer. Questions concerning potential risk applications should be directed to CC.

CC does not warrant or represent that any license, either express or implied, is granted under any CC patent right, copyright, artwork or other intellectual property right relating to any combination, machine or process which CC product or services are used. Information published by CC regarding third-party products or services does not constitute a license from CC to use such products or services or a warranty or endorsement thereof. Use of such information may require a license from a third party under the patents or other intellectual property of the third party, or a license from CC under the patents or other intellectual property of CC.

Reproduction of information in CC data sheets or web site is permissible only if the reproduction is without alteration and is accompanied by associated warranties, conditions, limitations and notices. Reproduction of this information with alteration is an unfair and deceptive business practice. CC is not responsible or liable for such altered documents.

Resale of CC products or services with statements different from or beyond the parameters stated by CC for that product or service voids all express and implied warranties for the associated CC product or service and is an unfair or deceptive business practice. CC is not responsible for any such statements.

Contacting Cardinal Components

Cardinal Components
19013 36th Ave. West
Lynnwood, WA 98036-5761
U.S.A.

Tel: 973-785-1333
Fax: 425.776.2760
email: sales@cardinalxstal.com
URL: www.cardinalxstal.com