

Field Programmable Blank Oscillator

Series CPP

- Programmed with the PG-3000, PG-3100 field oscillator programming instrument within seconds
- Can be programmed twice
- Standard Package Options
- Also available in 2.7 V

Part Numbering Example: CPP C 1 L Z - A5 B6 - XX.XXXX TS

| CPP | C | 1 | L | Z | A5 | B6 | XX.XXXX | TS |
|--------|---------------------|---|-------------------------|---|---|---|-----------------------|-------------------------------|
| SERIES | OUTPUT | PACKAGE STYLE | VOLTAGE | ADDED FEATURES | OPERATING TEMP. | STABILITY | FREQUENCY | TRI-STATE |
| CPP | C = CMOS T = TTL | 1 = Full Size 4 = Half Size 5 = 3.2X5 Ceramic 7 = 5X7 Ceramic 8 = PLASTIC SMD | Blank = 5V L = 3.3 V | Blank = Bulk T = Tube Z = Tape and Reel | Blank = 0°C +70°C A5 = -20°C +70°C A7 = -40°C +85°C | B6 = ±100 ppm BP = ±50 ppm BR = ±25 ppm | 0.500 ~133.000 MHz | TS = Tri-State PD=PowerDwn |

Specifications:

| Description | Min | Typ | Max | Unit |
|---|-------------------------------------|-----|-------------------|-------------------|
| Frequency Range: Programmable to Any Discrete Frequency | 0.5 | | 133.000 | MHz |
| Available Stability Options: | -100 -50 -25 | | 100 50 25 | ppm ppm ppm |
| Programmable Supply Voltage: (1–133 MHz) | 4.5 | 5.0 | 5.5 | V |
| (1–100 MHz) | 3.0 | 3.3 | 3.6 | V |
| Operating Temperature Range Options: | 0 -20 -40 | | +70 +70 +85 | °C °C °C |
| Storage Temperature: | -55 | | +125 | °C |
| Aging (PPM/Year) Ta=25C, Vdd=5/3.3V | | | ±5 | |
| Programmable Output Level: | TTL/CMOS | | | |
| Packaging: | Tape and Reel (1K per Reel) Tube | | | |

Operating Conditions:

| Description | Min | Max | Unit |
|--|-----|-----|------|
| Vdd Supply Voltage | 3.0 | 5.5 | V |
| CTTL Max Capacitive Load on outputs for TTL levels 4.5V–5.5V Vdd ≤ 40 MHz 4.5V–5.5V Vdd > 40–133 MHz | | 50 | pF |
| | | 25 | pF |
| CCMOS Max Capacitive Load on outputs for CMOS levels 4.5V–5.5V Vdd, ≤ 66 MHz 4.5V–5.5V Vdd, >66–133 MHz 3.0V–3.6V Vdd, ≤ 40 MHz 3.0V–3.6V Vdd, >40–100 MHz | | 50 | pF |
| | | 25 | pF |
| | | 30 | pF |
| | | 15 | pF |



Field Programmable Blank Oscillator

Series **CPP**

- Programmed with the PG-3000, PG-3100 field oscillator programming instrument within seconds
- Can be programmed twice
- Standard Package Options

Electrical Characteristics

| Description | TEST CONDITIONS | Min | Typ | Max | Unit |
|---|---|--|------------|---------------------------|----------|
| Input Characteristics (Pin 1): | | | | | |
| V _{IL} , Low-Level Input Voltage TO DISABLE OUTPUT | 4.5–5.5V V _{dd} 3.0–3.6V V _{dd} | | | 0.8 0.2V _{dd} | V V |
| V _{IH} , High-Level Input Voltage TO ENABLE OUTPUT Or OPEN | 4.5–5.5V V _{dd} 3.0–3.6V V _{dd} | 2.0 0.7V _{dd} | | | V V |
| I _{IL} , Input Low Current I _{IH} , Input High Current | V _{IN} = 0V V _{IN} = V _{dd} | | | 10 5 | μA μA |
| Output Characteristics: | | | | | |
| V _{OL} , Low-Level Output Voltage | 4.5V–5.5V V _{dd} , 16 mA I _{oL} 3.0V–3.6V V _{dd} , 8 mA I _{oL} | | | 0.4 0.4 | V V |
| V _{OHTTL} , High-level Output Voltage TTL | 4.5V–5.5V V _{dd} , -16 mA I _{oL} | 2.4 | | | V |
| V _{OHCOS} , High-level CMOS Voltage | 4.5V–5.5V V _{dd} , -16 mA I _{oL} 3.0V–3.6V V _{dd} , -8 mA I _{oL} | V _{dd} -0.4 V _{dd} -0.4 | | | V V |
| Power Supply Current: (unloaded) | 4.5–5.5 V _{dd} , OUTPUT FREQ ≤ 133 MHz 3.0–3.6 V _{dd} , OUTPUT FREQ ≤ 100 MHz | | | 45 25 | mA mA |
| Standby Current: | | | 10 | 50 | μA |
| Pull-Up (Pin 1) | 4.5–5.5 V _{dd} , V _{IN} = 0V 4.5–5.5 V _{dd} , V _{IN} = 0.7V | 1.1 50 | 3.0 100 | 8.0 200 | MΩ KΩ |
| Tri-State Leakage Current | 5.0 V _{dd} | | 20 | | μA |
| Output Enable Mode: | Output is Tri-Stated | | | | |
| Power Down Mode: | Output is Tri-Stated. | | | | |

" Tristate Internal pull up Output active when high"

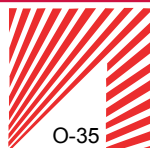

Field Programmable Blank Oscillator

Series CPP

- Programmed with the PG-3000, PG-3100 field oscillator programming instrument within seconds
- Can be programmed twice
- Standard Package Options

Output Clock Switching Characteristics

| Description | TEST CONDITIONS | Min | Typ | Max | Unit |
|--|--|-----|----------|-------------------|-----------|
| Duty Cycle: TTL @ 1.4 V 4.5-5.5 Vdd | ≤ 50 MHz, C _L = 50 pF | 45 | | 55 | % |
| | 50–66 MHz, C _L = 15 pF | 45 | | 55 | % |
| | 66–125 MHz, C _L = 25 pF | 40 | | 60 | % |
| | 125–133 MHz, C _L = 15 pF | 40 | | 60 | % |
| Duty Cycle: CMOS @ Vdd/2 4.5-5.5 Vdd 3.0–3.6 Vdd | ≤ 66 MHz, C _L ≤ 25 pF | 45 | | 55 | % |
| | 66–125 MHz, C _L ≤ 25 pF | 40 | | 60 | % |
| | 125–133 MHz, C _L ≤ 15 pF | 40 | | 60 | % |
| | ≤ 40 MHz, C _L ≤ 30 pF | 45 | | 55 | % |
| Output Clock Rise/Fall | 0.8V–2.0V, 4.5-5.5 Vdd, C _L = 50 | | | 1.8 | ns |
| | 0.8V–2.0V, 4.5-5.5 Vdd, C _L = 25 | | | 1.2 | ns |
| | 0.8V–2.0V, 4.5-5.5 Vdd, C _L = 15 | | | 0.9 | ns |
| | 0.2–0.8Vdd, 4.5-5.5 Vdd, C _L = 50 | | | 3.4 | ns |
| | 0.2–0.8Vdd, 3.0–3.6 Vdd, C _L = 30 | | | 4.0 | ns |
| | 0.2–0.8Vdd, 3.0–3.6 Vdd, C _L = 15 | | | 2.4 | ns |
| Start Up Time | From power on | | | 2 | ms |
| Power Down Delay Time Synchronous Asynchronous | PWR_DWN pin LOW to output Hi-Z | | T/2 | T+10 | ns |
| | | | 10 | 15 | ns |
| Output Disable Time Synchronous Asynchronous | OE pin LOW to output Hi-Z T = Frequency oscillator period | | T/2 | T+10 | ns |
| | | | 10 | 15 | ns |
| Output Enable Time | | | T | 1.5 T + 25 | ns |
| RMS Period Jitter: | ≤ 33.000 MHz | | 40 | 50 | ps |
| | > 33.000, MHz | | 30 | 40 | ps |
| Peak to Peak * | ≤ 33.000 MHz | | 100 | 250 | ps |
| | > 33.000 MHz | | 75 | 175 | ps |

* Jitter tested at > 1,000,000 samples, exceeding JEDEC std JESD65.

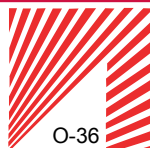

Field Programmable Blank Oscillator

Note: Bypass Vdd to GND with a 0.01 μ F capacitor

Style 1 Full Size 14 Pin Dip

STYLE 1 FULL SIZE 14 PIN DIP

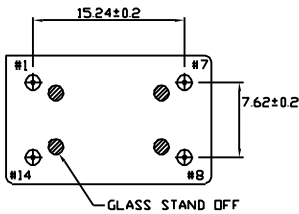
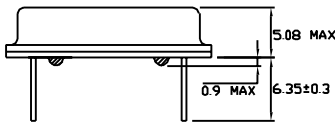
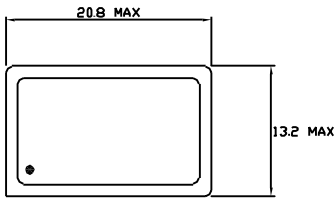

PIN FUNCTION
 1 CONTROL
 7 GND
 8 OUTPUT
 14 Vdd

Style 4 Half Size 8 Pin Dip

STYLE 4 HALFSIZE 8 PIN DIP

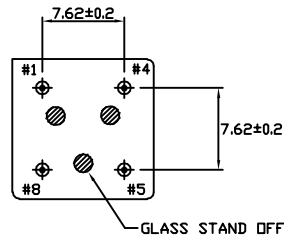
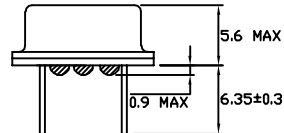
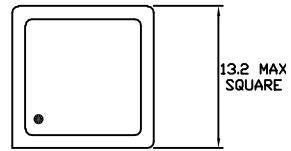

PIN FUNCTION
 1 CONTROL
 4 GND
 5 OUTPUT
 8 Vdd

Style 7 5x7 Ceramic SMD

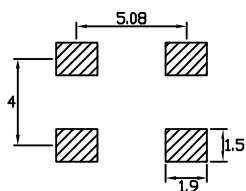
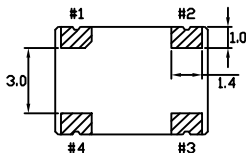
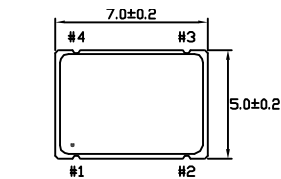

PIN FUNCTION
 1 CONTROL
 2 GND
 3 OUTPUT
 4 Vdd

Style 8 Plastic SMD

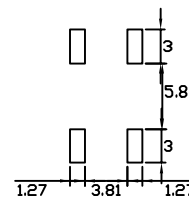
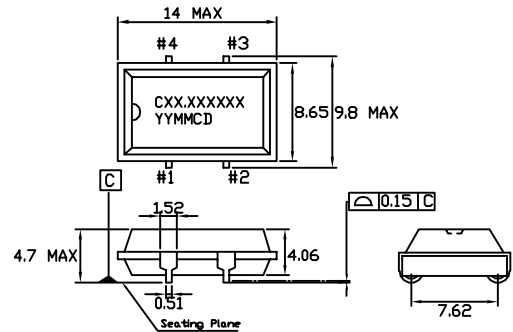

PIN FUNCTION
 1 CONTROL
 2 GND
 3 OUTPUT
 4 Vdd

Field Programmable Blank Oscillator

Note: Bypass Vdd to GND with a 0.01 μ F capacitor

Style 5 3.2x5 Ceramic SMD

