

**Programmable LVDS Oscillator**

Platinum Series **CHL**

- \* LVDS Output
- \* Fast Delivery
- \* Industry Standard Packaging

**Applications**

- \* Serial Communications
- \* Routers
- \* Switches
- \* WAN Interfaces
- \* Test Equipment



**Part Numbering Example: CHL Z - A5 BP - 222.5792 TS**

CHL	Z	A5	BP	222.5792	TS
SERIES	PACKAGING OPTIONS	OPERATING TEMP.	STABILITY	FREQUENCY	TRI-STATE
CHL	Blank = Bulk Z = Tape and Reel	Blank = 0°C ~ +70°C A5 = -20°C ~ +70°C A7 = -40°C ~ +85°C	Blank = ±100 ppm BP = ±50 ppm		TS = Tri-State

Specifications:	Min	Typ	Max	Unit
Frequency Range:	200		800	MHz
Stability:	-50		+ 50	ppm
Supply Voltage:	3.135	3.3	3.465	V
Vdd Rise Time:	100			µS
Operating Temperature:	-20		+ 70	°C
Storage Temperature:	-55		+ 125	°C
Duty Cycle:	45		55	%
Start-Up Time:		3	10	mS
Aging: (ppm/1st Year) Ta=25C, Vdd=3.3V			5	ppm
Supply Current:			140	mA
Short Circuit Current:		± 50		mA
RMS Period Jitter:		15		pS
RMS Integrated Jitter: 12kHz to 20MHz		20		pS
Phase Noise @ 10kHz:			-90	dBc/Hz
Output Voltage: Voh Vol			1.6 0.9	V V
Output Differential Voltage:	240	350	460	mV
Rise/Fall Time:		0.4	0.8	nS
Output Level:	LVDS			
Packaging:	Tape and Reel 1000 pcs per Reel			

**CHL**

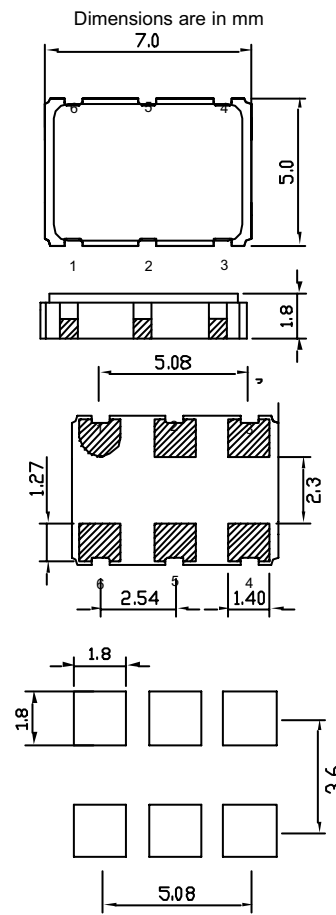

- PIN Function**
- 1 OE (CMOS)
  - 2 Do Not Connect
  - 3 Ground
  - 4 LVDS +
  - 5 LVDS -
  - 6 Vdd

Solder Pad Layout

**LVDS Levels Test Circuit**

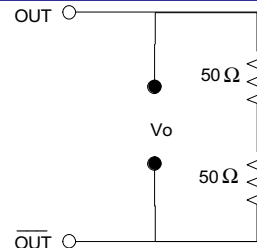

Tristate internal pull up resistor--  
output active when high

